

Drawing ID

C-90LFX

**Product Info.**

Finish	Code
Polish	C-90LFM
Satin	C-90LFS
Texture Black	C-90LFB

Dimensions

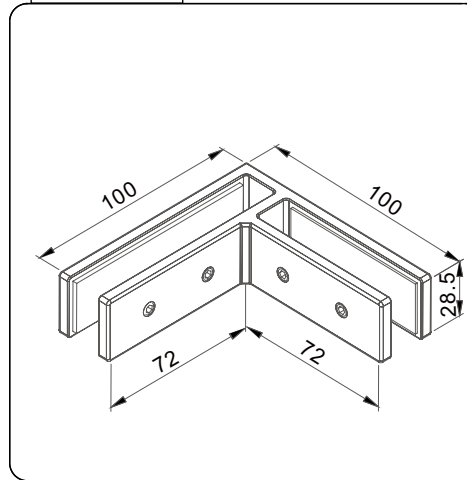

Dimensions

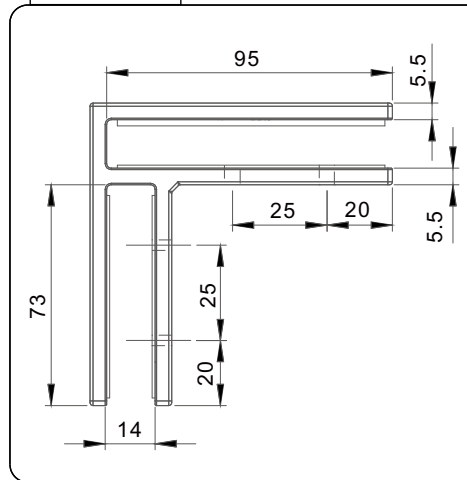

Top View

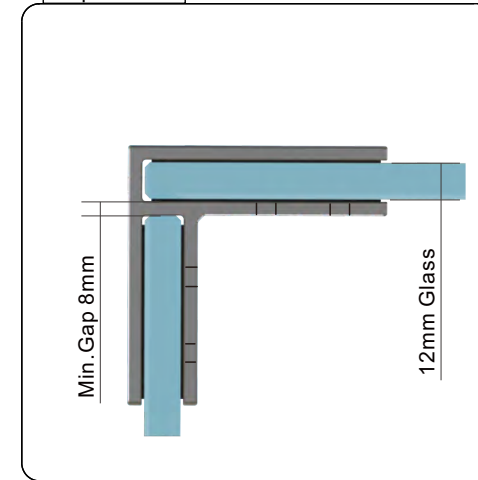

**MATERIAL:**

Duplex 2250 Stainless Steel

**CATALOGUE AND DESCRIPTION:**

- > Glass Fixing System
- > Glass Clamp
- > Friction Fit Glass to Glass 90° Clamp

**NOTES:**

This drawing and or specification is the property of Silver Stone Hardware Pty Ltd - and must be returned to them on request. Unauthorised use may result in Legal Action. Its contents must not be made public, nor copied, nor used directly or indirectly in any way.

**SILVER STONE HARDWARE PTYLID**

56-62 Bryant Street, Padstow, NSW 2211  
 T: (02) 9792 2955 M: 0452 526 680  
[www.silverstonehardware.com.au](http://www.silverstonehardware.com.au)  
[sales@silverstonehardware.com.au](mailto:sales@silverstonehardware.com.au)